

MARTIN® GUARDABELT™ Impact Cradles

Installed under a belt conveyor loading zone, the **MARTIN® GUARDABELT™ Impact Cradles** absorb the force of falling material to prevent damage to the belt and structure. The impact cradles stabilize the belt line to prevent material escape.



BENEFITS

- **Steel Reinforcement for Impact Bars**
Each impact bar is reinforced with a bed of steel angles.
- **Adjustable Supports Make Installation Easy**
Wings adjust to match any standard trough angle.
- **Allows Compensation for Wear**
Eccentrics in wing supports allow outer bars five degrees of wear adjustment.
- **Durable GUARDABELT™ Impact Bars**
Rugged bars are composed of a top layer of low friction UHMW and a lower layer of energy-absorbing SBR rubber.
- **Simple Bar Replacement**
Impact bars are each secured with four T-Bolts.
- **Meets CEMA Design Standards**
The GUARDABELT™ Impact Cradle conforms to CEMA Standard No. 502-1998 & 575-2000 Bulk Material Belt Conveyor Troughing and Return Idlers.
- **Engineered to Fit Your Conveyor**
The GUARDABELT™ Medium-Duty Impact Cradle is available for belts from 24 to 72 inches (500 to 2000 mm) wide.
- **Rugged Structure Stands Up to Abuse**
Sturdy cradle base of MARTIN® TRAC-MOUNT™ Cradle is constructed from four I-beams. Light-Duty and Medium-Duty Cradles are formed channels.

MARTIN® TRAC-MOUNT™ IMPACT CRADLE

Belt Width† in. (mm)	# of Bars	Impact Cradle Part Number**	Standard Base Cradle		
			Stringer Width in. (mm)	Mounting Centers in. (mm)	Ship Weight lb (kg)
24 (500-650)	6	30688-24XXX	36 (914)	33 (838)	577 (262)
30 (650-800)	6	30688-30XXX	42 (1066)	39 (991)	610 (277)
36 (800-1000)	7	30688-36XXX	48 (1219)	45 (1143)	645 (293)
42 (1000-1200)	9	30688-42XXX	54 (1317)	51 (1295)	840 (381)
48 (1200-1400)	10	30688-48XXX	60 (1529)	57 (1448)	930 (422)
54 (1400-1600)	10	30688-54XXX	66 (1676)	63 (1600)	969 (440)
60 (1600-1800)	13	30688-60XXX	72 (1829)	69 (1752)	1159 (526)
72 (1800-2000)	13	30688-72XXX	84 (2133)	81 (2057)	1219 (553)
84 (2000-2200)	16	30688-84XXX	96 (2438)	93 (2362)	1453 (659)
96 (2200-2400)	19	30688-96XXX	108 (2743)	105 (2667)	1684 (764)

† Metric dimensions indicate industry standards for metric belting, rather than a straight conversion.

* For Wide Base GUARDABELT™ Impact Cradle, add 6 inches (150 mm) to Stringer Width and Mounting Centers dimensions.

** Replace the first XX with the conveyor's troughing angle (20°, 35°, 45°); replace the final X with S for Standard Cradle or W for Wide Base Cradle.

TECHNICAL DATA SHEET

GUARDABELT™ IMPACT CRADLES

Belt Width in. (mm)	# of Bars	Light-Duty Impact Cradle 4 ft. Bar P/N*	Shipping Weight		Medium-Duty Impact Cradle 4 ft. Bar P/N*	Shipping Weight		Medium-Duty Impact Cradle 5 ft. Bar P/N*	Shipping Weight	
			Standard Base lb (kg)	Wide Base lb (kg)		Standard Base lb (kg)	Wide Base lb (kg)		Standard Base lb (kg)	Wide Base lb (kg)
24 (500-650)	6	36010-24X	421 (189)	450 (204)	36318-24X	606 (275)	637 (289)	36516-24X	636 (288)	667 (302)
30 (650-800)	7	36010-30X	494 (222)	515 (233)	36318-30X	690 (313)	721 (327)	36516-30X	734 (333)	765 (346)
36 (800-1000)	7	36010-36X	505 (227)	527 (239)	36318-36X	720 (327)	752 (341)	36516-36X	764 (346)	796 (361)
42 (1000-1200)	9	36010-42X	647 (291)	676 (306)	36318-42X	882 (400)	913 (414)	36516-42X	952 (431)	983 (446)
48 (1200-1400)	10	36010-48X	720 (324)	742 (336)	36318-48X	966 (438)	997 (452)	36516-48X	1050 (476)	1081 (490)
54 (1400-1600)	12	N/A			36318-54X	1151 (522)	1184 (537)	36516-54X	1262 (572)	1295 (587)
60 (1600-1800)	13				36318-60X	1237 (561)	1270 (576)	36516-60X	1361 (617)	1393 (632)
72 (1800-2000)	16				36318-72X	1508 (684)	1554 (705)	36516-72X	1672 (758)	1718 (779)

* Replace X with S for standard stringers or W for wide base stringers
For wide cradles, add 6 inches (152 mm) to column stringer width and mounting centers.

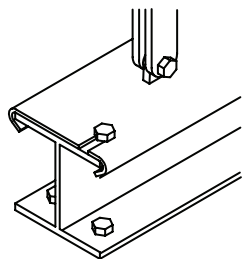

MARTIN® TRAC-MOUNT™
Design incorporates impact bars mounted on sliding sleeves to reduce maintenance. Bars slide to one side or the other.

NOTES

GUARDABELT™ Impact Cradles are installed so that bars in the center of the cradle are set slightly below—3/4 in. (19 mm) to 1/2 in. (13 mm)—the unloaded belt's line of travel. This allows the belt to absorb impact while avoiding continuous friction and wear if the belt is running empty. The wing bars on the sides of the cradle are installed in line with the idlers to allow effective sealing of the transfer point.

When installing one or more GUARDABELT™ Impact Cradles, it is necessary to verify there is adequate power in the conveyor drive to compensate for the additional frictional drag. Consult Martin Engineering for additional information.

Standard base stringer width is the belt width plus 12 in. (305 mm). Mounting centers width is the belt width plus 9 in. (229 mm). Wide base stringer width is the belt width plus 18 in. (457 mm). Mounting centers width is belt width plus 15 in. (381 mm).

DIMENSIONS - in. (mm)

TRAC-MOUNT™ Impact Cradle

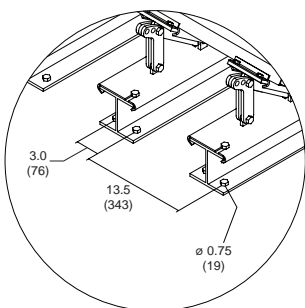

Light-Duty Cradle

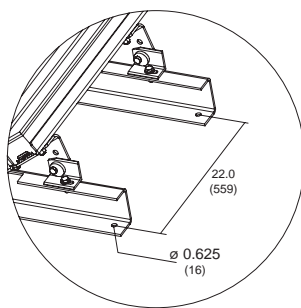

Medium-Duty Cradle

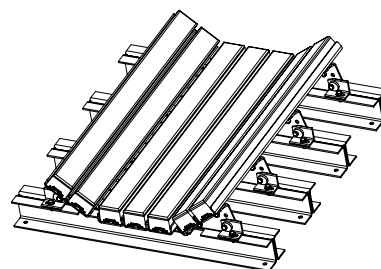
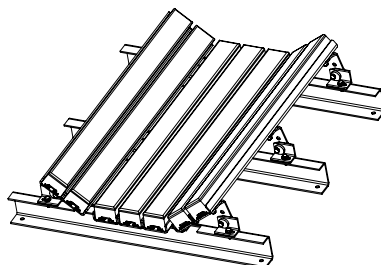
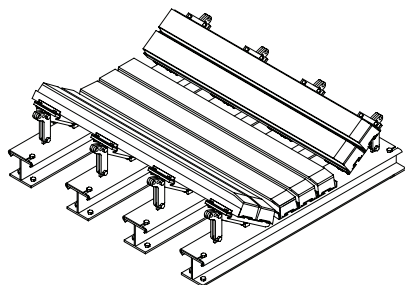
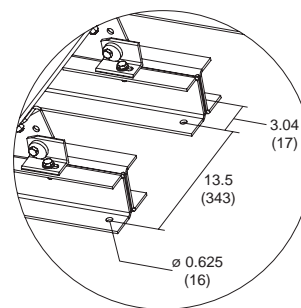

TECHNICAL DATA SHEET

SELECTION GUIDE

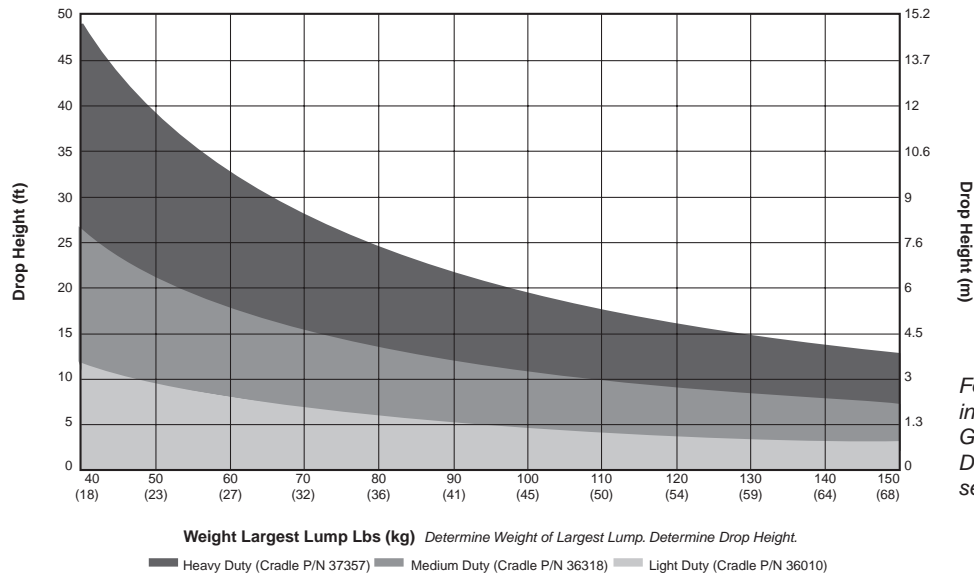

For additional information on the GUARDABELT™ Heavy-Duty Impact Cradle see Form No. L3631.

Belt Width	Non-Impact	Light-Duty	Medium-Duty		Heavy-Duty
	GAS*	LD GAB	MD GAB	TRAC-MOUNT™ GAB	HD GAB*
24" S-Base	36700-24s	36010-24s	36318-24s	30688-24xxs	N/A
24" W-Base	36700-24w	36010-24w	36318-24w	30688-24xxw	N/A
30" S-Base	36700-30s	36010-30s	36318-30s	30688-30xxs	N/A
30" W-Base	36700-30w	36010-30w	36318-30w	30688-30xxw	N/A
36" S-Base	36700-36s	36010-36s	36318-36s	30688-36xxs	37357-36xxExs
36" W-Base	36700-36w	36010-36w	36318-36w	30688-36xxw	37357-36xxExw
42" S-Base	36700-42s	36010-42s	36318-42s	30688-42xxs	37357-42xxExs
42" W-Base	36700-42w	36010-42w	36318-42w	30688-42xxw	37357-42xxExw
48" S-Base	36700-48s	36010-48s	36318-48s	30688-48xxs	37357-48xxExs
48" W-Base	36700-48w	36010-48w	36318-48w	30688-48xxw	37357-48xxExw
54" S-Base	36700-54s	N/A	36318-54s	30688-54xxs	37357-54xxExs
54" W-Base	36700-54w	N/A	36318-54w	30688-54xxw	37357-54xxExw
60" S-Base	36700-60s	N/A	36318-60s	30688-60xxs	37357-60xxExs
60" W-Base	36700-60w	N/A	36318-60w	30688-60xxw	37357-60xxExw
72" S-Base	36700-72s	N/A	36318-72s	30688-72xxs	37357-72xxExs
72" W-Base	36700-72w	N/A	36318-72w	30688-72xxw	37357-72xxExw
* For additional information on the MARTIN® GUARDABELT™ Heavy-Duty Impact Cradle see Form No. L3631. For the MARTIN® GUARDASEAL™ Belt Support System see Form No. L3298-03. Or contact your Martin Engineering representative at 1-800-544-2947.				Replace xx with trough angle.	Replace xx with trough angle.
					Replace X in Ex with E6 or E7 class idlers.

OPTIONS

- Light- and Medium-Duty Impact Cradles ship unassembled. Assembly available by adding an A to the end of the part number.
- Standard Impact Cradle length for light, medium and TRAC-MOUNT™ Cradles is 4 ft. (1220 mm).
- Contact Martin Engineering for specifications on non-standard cradle length.
- All belt support cradles available in picking idler configuration.

TECHNICAL DATA SHEET

GUARDABELT™ IMPACT BAR

Characteristics	
Coefficient of Friction	0.5
Service Temperature Range	-20° to 140°F (-29° to 60°C)
Bar Construction	
Bearing Layer	UHMW Polyethylene
Absorption Layer	50-Durometer SBR Rubber
T-Slot	Aluminum
Fasteners	1/2-inch diameter T-Bolts

GUARDABELT™ Impact Bars absorb the punishment of loading zone impact, preventing damage to equipment and stabilizing the belt line to control fugitive material. Each bar is anchored with T-Bolts for easy replacement.

GUARDABELT™ BAR DIMENSIONS - in. (mm)

	A	B	C	D	E	F	G	H	P/N
UHMW 48-inch Bar	3 (75)	3.7 (94)	4.0 (102)	0.75 (19)	1.5 (38)	0.51 (13)	0.5 (12)	48 (1220)	31617
UHMW 60-inch Bar	3 (75)	3.7 (94)	4.0 (102)	0.75 (19)	1.5 (38)	0.51 (13)	0.5 (12)	60 (1524)	33816

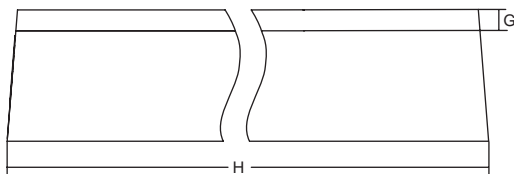
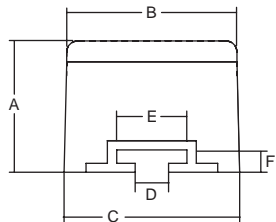

UHMW BAR

Sample Chemical Resistance Ratings At 70°F (21°C)	
Anhydrous Ammonia	Good
Benzene	Poor
Borax	Good
Caustic Soda	Good
Chlorine (Wet, 10%)	Fair
Diesel Fuel	Good
Ethyl Alcohol (Ethanol)	Good
Ethylene Glycol	Good
Gasoline (Unleaded)	Good
Methylene Chloride	Fair
Mineral Oil	Good
Nitric Acid (20%)	Good
Nitric Acid (50%)	Poor
Sodium Chloride	Good
Sulfur	Good
Sulfuric Acid (50%)	Good

ORDER INFORMATION

Cradle Components	P/N
T-Bolt Assembly Includes each of the following:	31775-H
T-Bolt	31775
Flat Washer	17328
1/2" Nut	11771
1/2" Compression Washer	11750

CHEMICAL EXPOSURE

GUARDABELT™ Impact Bars are suitable for use with most industrial chemicals. For additional information, see Martin Engineering's "Guide to Chemical Resistance."



Martin Engineering USA
One Martin Place
Neponset, IL 61345-9766 USA
800 544 2947 or 309 852 2384
Fax 800 814 1553
www.martin-eng.com

Subject to change without prior notice.
Quality Management System Certified by DNV - ISO 9001

QUALITY MANAGEMENT SYSTEM
CERTIFIED BY DNV
== ISO 9001:2008 ==

Problem Solved™

Form No. L3630-10/11
© Martin Engineering Company 2002, 2011